

# PT00808 Wireless Current Loop with I/O Options

The PT00808 is a wireless system, which integrates an ISM radio and I/O ports. It has been designed to be used for the bi-directional interfacing of digital I/O signals and uni-directional interfacing of a 4-20mA current loop. This device enables the user to link numerous control and data signals within high interference environments without the need for costly cabling and conduit runs, thus eliminating most of the permit and labor costs for layout planning and installation.

The PT00808 is designed to operate within harsh industrial environments. It can be used in a configuration, in which it acts as a backup for a wired system, and can temporarily replace mechanically damaged wires and reduce the system down time.

**Features:**

- o This is a two box solution for point-to-point radio communication:
  - o BOX A "Current Loop Analog RX"
  - o BOX B "Current Loop Analog TX"
- o Uses a bi-directional ISM radio system operating within the license free 869MHz RF band
- o Operating range:
  - o 1km radio link range in open space
  - o 100m unidirectional radio link range in an industrial environment
  - o Up to 4km radio link range with a directional antenna
- o Analog input to output transfer accuracy better than 0.1%
- o Two digital inputs and one digital output (On BOX A)
- o IP65 enclosures with mechanical shock and vibration resistance
- o RF antenna with SMA mounting option on the device enclosure
- o Galvanically Isolated IO ports (analog and digital)
- o Programmable behavior of I/O ports in the event of an error
- o IrDA port for configuration download
- o Expandable point-to-multipoint network



**Designed to meet EC Declaration of Conformity requirements:**

- o EN 300 220 EMC and Radio spectrum Matters
- o EN 61000-6-2 Immunity standard for industrial environments
- o EN 61000-6-4 Emission standard for industrial environments

**Applications:**

- o PLC/RTU extension
- o Sensor interfacing, especially for sensors located on moving machinery
- o Monitoring of force, level, temperature, pressure, etc.

**BLOCK DIAGRAM of PT00808 Wireless Current Loop with I/O Options (point-to-point network)**

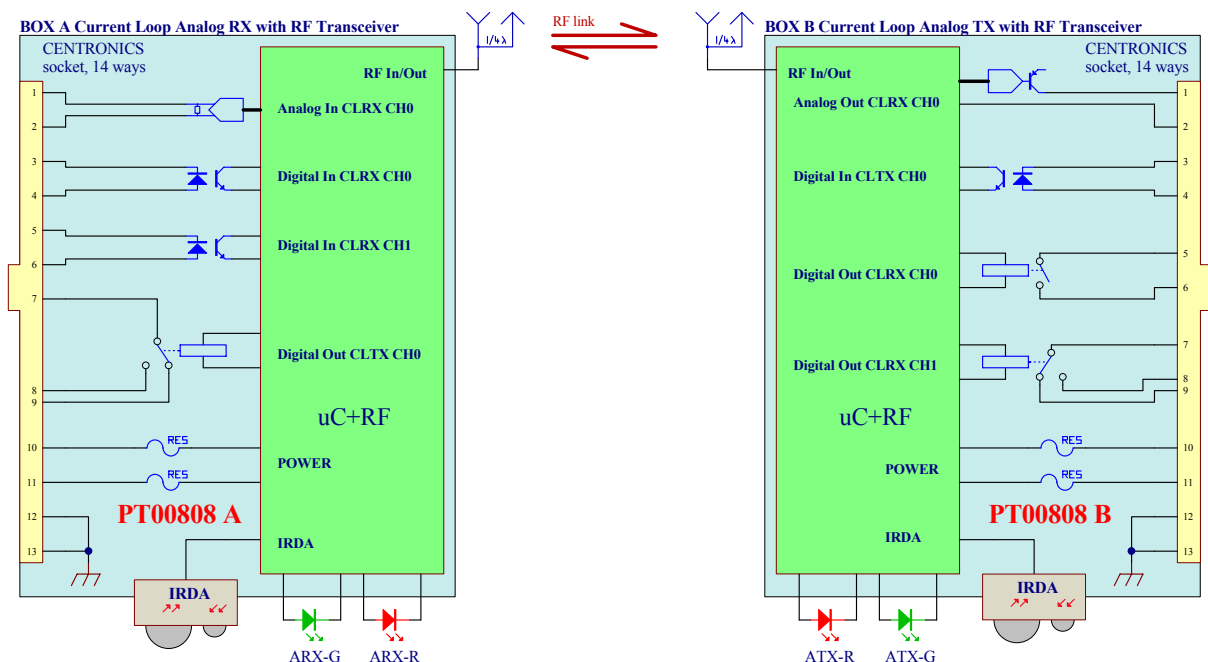

## Technical characteristics of PT00808 Wireless Current Loop with I/O Options

Device characteristics	Device description	The PT00808 is a wireless system that integrates an ISM radio & I/O ports. It is designed for bi-directional interfacing of digital I/O signals and uni-directional interfacing of a 4-20mA current loop. The system includes: <ul style="list-style-type: none"> <li>• BOX PT00808A Current Loop Analog Receiver with RF Transceiver with omni-directional aerial</li> <li>• BOX PT00808B Current Loop Analog Transmitter with RF Transceiver with omni-directional aerial</li> </ul>	
	Typical applications	PLC/RTU extension; sensor interfacing especially for sensors located on moving parts or mobile machinery and used to: monitor force, levels, temperature, pressure etc. It can be used in a configuration, in which it acts as a backup for a wired system, and can temporarily replace mechanically damaged wires and reduce the system down time.	
	Number and type of measurement channels	<ul style="list-style-type: none"> <li>• One analog current loop input wirelessly linked to an analog current source output</li> <li>• Two digital inputs wirelessly linked to two independent dry contact outputs</li> <li>• One dry contact output wirelessly controlled from the digital input</li> </ul>	All measurement channels are galvanically isolated; response behaviors of output ports programmable.
	Number and type of communication channels	<ul style="list-style-type: none"> <li>• RF ISM</li> <li>• IrDA 1.0 (unit system maintenance only)</li> </ul>	
	Power source	DC 9-36V, allowed AC 50/60Hz component up to 20% of DC working value; power consumption 1.7W max	
	An integrated module for diagnostics and visualization of data link	Two LEDs	
	Operating temperature range	Full industrial grade range of -40°C to 85°C	According to IEC 68-2-1,2,14
	Enclosure: index of protection, material and enclosure dimensions	IP65; polyester enclosure; 120x80x55	
	Mounting position	Vertical	
	EC Declaration of Conformity	EN 300 220, EN 61000-6-2, EN 61000-6-4, IEC 68-2-6, IEC 62-2-27	
Details RF specifications	RF PA output power (max)	250mW 50R	Programmable output power
	Frequency band	869.40-869.65MHz	
	Modulation	FSK narrow band, listen before talk	
	Type of aerial	Aerial on SMA socket; 1/4 lambda; polarization vertical	
Details on analog (current loop) section	Range of input/output current	3mA to 25mA (design to support 4mA to 20mA current loop)	Circuit protection in acc. with EN 50020 category 'ia' or 'ib' or EN61000-6-5 is available on request
	Input impedance	120R	
	Maximum impedance of output load	200R	
	Processing resolution of digital conversions	16 bit	ADC and DAC
	Analog output refresh rate (minimum)	250msec	
	Input current to output current transfer accuracy	Less than 0.1%	Over full scale and temperature range
	Input current to output current transfer repeatability	Less than 0.03%	Over full scale and temperature range
Type of input/output connector	CENTRONICS socket		
Details on digital I/O section	Digital input, type and range	AC/DC, 10-68V	Circuit protection in acc. with EN 50020 category 'ia' or 'ib' or EN61000-6-5 is available on request
	Digital output, type and range	Dry contact, NO, 100V 500mA DC	
	Digital output refresh rate (minimum)	250msec	
	Type of input/output connector	CENTRONICS socket	

**BLOCK DIAGRAM of PT00808 Wireless Current Loop devices point-to-multipoint network with PT00608 10Tbase Ethernet Bridge**

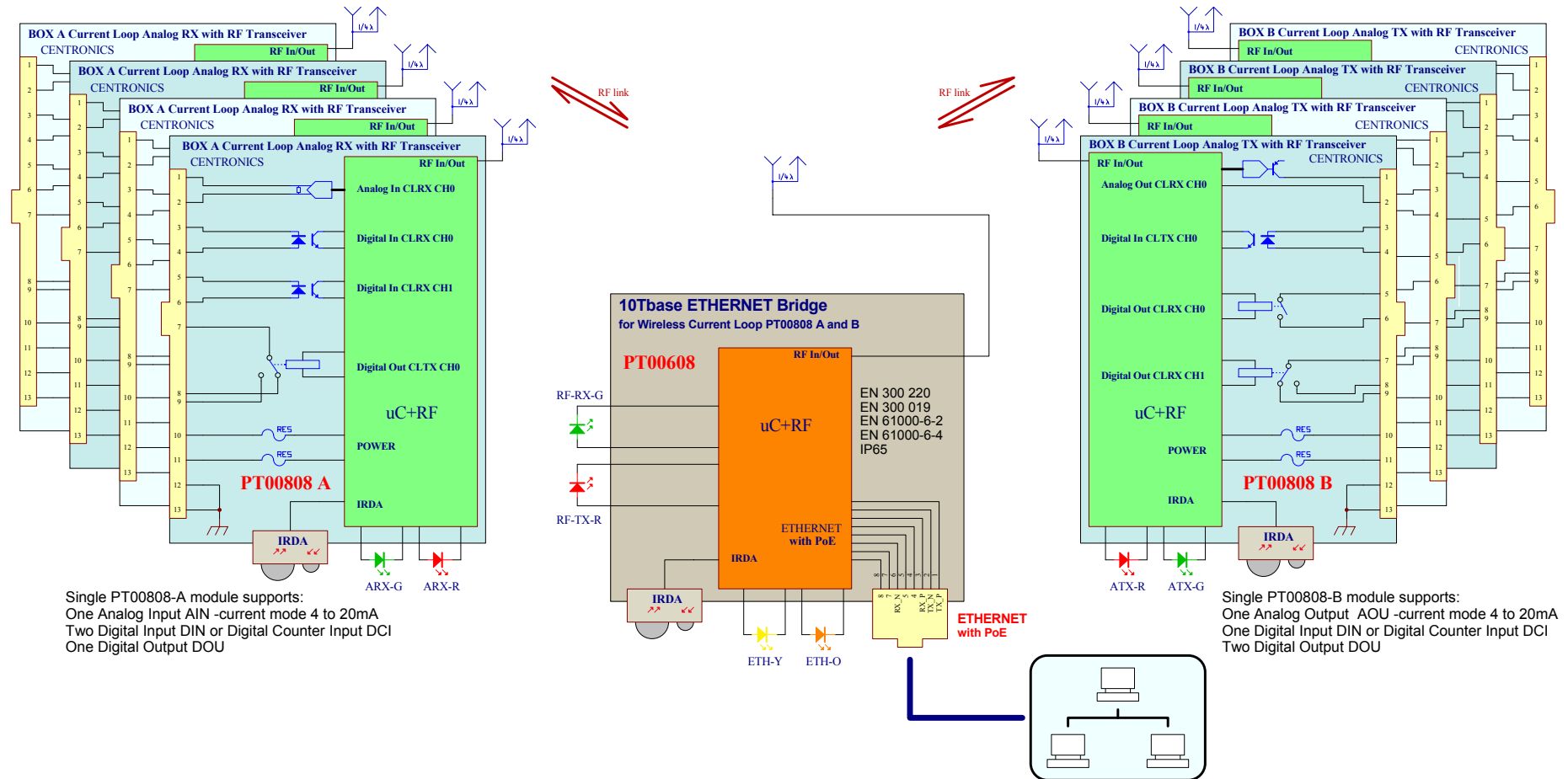

**List of modules compatible with PT00608 ISM to 10Tbase Ethernet Bridge**

- o PT00808-A Wireless Current Loop with I/O Options
- o PT00808-B Wireless Current Loop with I/O Options
- o **PT00109** ISM Wireless Geiger-Muller Radiation Detector for NORM ( <http://www.pelczar.com.pl/PT00109-0-SD-D-0001-EN.pdf> )

**Other presentations:**

- o **PT00108** Remote Bus/Tram Stop Request System with Support for the Physically Disabled ( <http://www.pelczar.com.pl/00108-0-0001-T54FQ8C-PPT-EN.PDF> )
- o **PT00509** Visible Light Communication (VLC) System for Road Safety ( <http://www.pelczar.com.pl/00509-0-0001-44U6578EA-PPT.PDF> )